

XOI Spec Sheet

Model: XOI33KS - XOI45KS

Sizes: 33-3/4" - 45-3/4" Depth: 18-7/16"

Features and Benefits:

- 1000 CFM high velocity blower optimally removes Smoke, Grease and Odors.
- 3 speed push button controls.
- Two 50W Halogen Lights - Provide brilliant illumination over the cooking surface.
- XOI33KS - Dimensions: 33-3/4" x 18-7/16" D x 11-1/2" Tall.
XOI45KS - Dimensions: 45-3/4" x 18-7/16" D x 11-1/2" Tall.
- Baffle Filters - Trap airborne smoke and grease particles. They can be easily be removed for dishwasher-safe cleaning.
- Mounting Height from cooking surface 27"-32".

Duct Options and Electrical Requirements:

- 8 inch duct required.
- Ductless Option for applications where no ducting in available.
- AC 120v-60Hz (6.2amp).

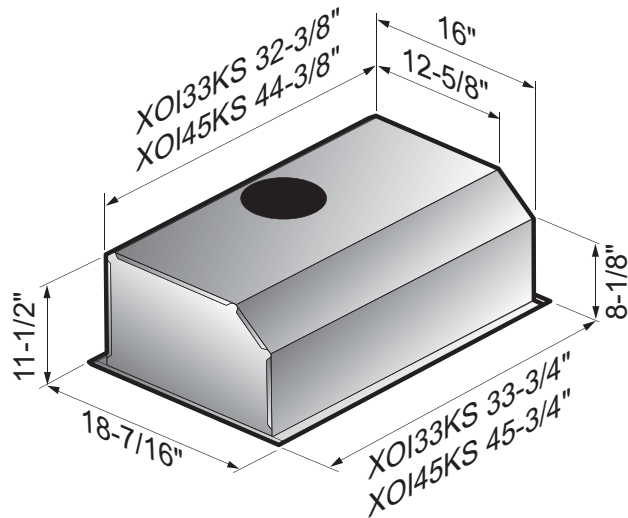

www.xoappliance.com

XO is Exclusively Distributed by:
Eastern Marketing Corp 24 Eisenhower Parkway Roseland,
New Jersey 07068 800-966-8300
www.easternmarketingcorp.com

All XO hoods are UL approved.

